

Prototipe 1 – DISTRIBUTION UNLIMITED CO. (HL¹, pg. 58)

The *DISTRIBUTION UNLIMITED CO.* will be producing the same new product at two different factories, and then the product must be shipped to two warehouses, where either factory can supply either warehouse. The distribution network available for shipping this product is shown below, where

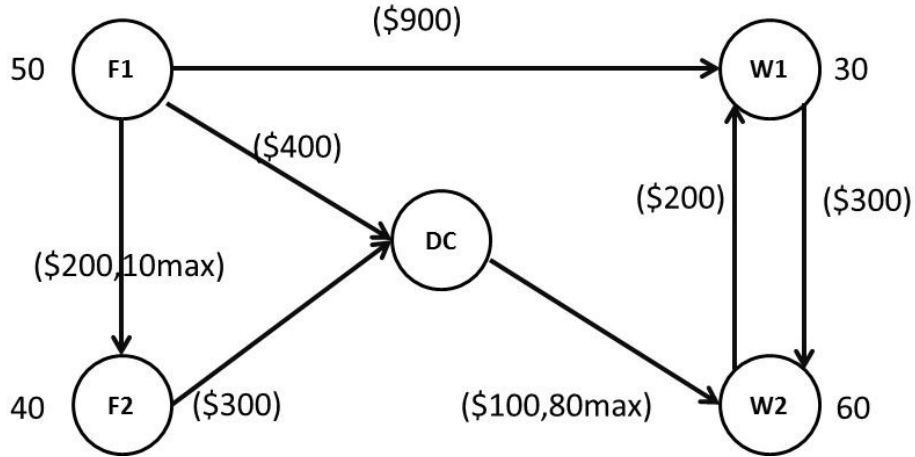

F1 and F2 are the two factories, W1 and W2 are the two warehouses, and DC a distribution centre, The amounts to be shipped from F1 and F2 are shown on their left, and the amounts to be received at W1 and W2 are showed on their right. Each arrow represents a feasible shipping lane. The cost per unit shipped through each shipping lane is shown next to the arrow. Also shown next to F1 → F2 and DC → W2 are the maximum amounts that can be shipped through these lanes. The other lanes have sufficient shipping capacity to handle everything these factories can send.

The decision to be made concerns how much to ship through each shipping lane. The objective is to minimize the total shipping cost.

Prototipe 2 – SEERVADA PARK (HL, §9.1, pg. 359)

SEERVADA PARK, has recently been aside for a limited amount of sightseeing and backpack hiking. Cars are not allowed into the park, but there is a narrow, winding road system trams and jeeps driven by the car park rangers. This road system is shown (without the curves) in the figure above, where location *O* is the entrance into the park; other letters designate the locations of ranger stations (and other facilities). The numbers give the distances of these winding roads in miles. The park contains a scenic wonder station *T*. A small number of trams are used to transport sightseers from park entrance to station *T* and back.

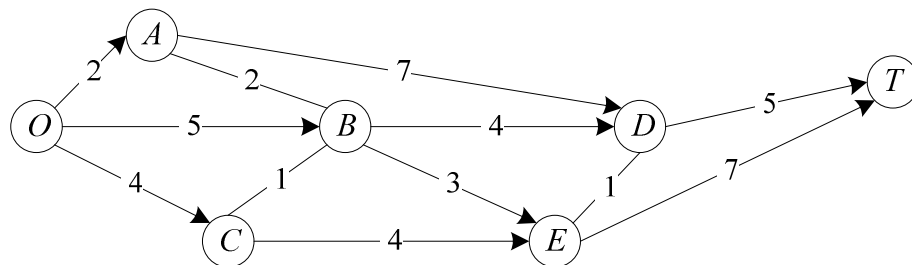

The park management currently faces two problems:

¹ Hillier, Lieberman, "Introduction to Operations Research", 9th ed., McGraw-Hill 2010.

- 1º) One is to determine which route from park entrance to station T has the smallest total distance for the operation of the trams.
- 2º) A second problem is that telephone lines must be installed under the roads to establish telephone communication among all stations (including the park entrance). Because the installation is both expensive and disruptive to the natural environment, lines will be installed under just enough roads to provide some connection between every pair of stations. The question is where the lines should be laid to accomplish this with minimum number of total miles of line installed.

Network Optimization Exercises

33. A manager needs to travel from Lisboa to Oslo. After consulting its travel agent, he noticed that the relevant connections are only the ones represented on the following graph, values in the arcs stand for the distances (in km) between cities:

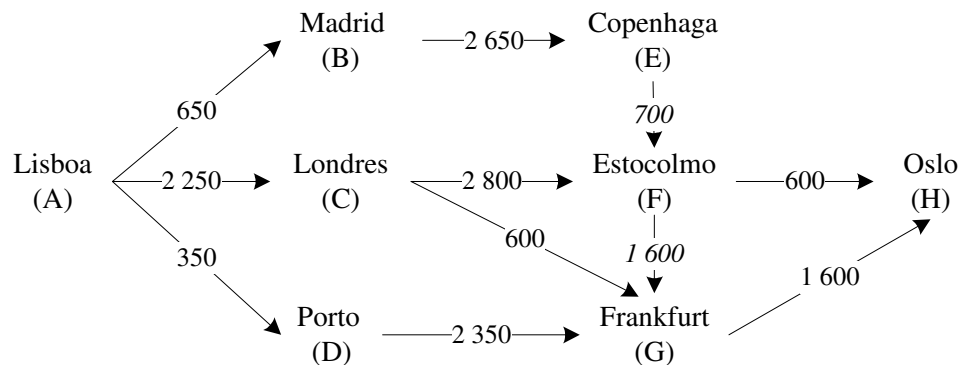

Assuming that the time spent in the trip can be considered proportional to the total distance travelled, find the minimum time connection between Lisboa and Oslo.

34. Sara just completed the high school with fantastic grades. As a gift, her parents decided to give her 21 000 $m.u.$ to buy and maintain a second hand car. As the maintenance costs grow fast with the age of the car she was told that she could replace it by an identical car, once or more, during the next three years, in case it minimizes total cost. They also promise a brand new car after the graduation that will be in four years. In the following table you find the relevant data about the problem the costs (evaluated in $m.u.$)

Purchase cost	Maintenance cost during year				Selling price at the end of year			
	1	2	3	4	1	2	3	4
12 000	2 000	3000	4 500	6 500	8 500	6 500	4 500	3 000

Help Sara to find the best strategy for the coming four years.

35. A municipality wants to build a road network to ensure the connection of six locations. Given the scarcity of resources is intended to minimize the total number of *km* of road to be constructed, however it should be possible to travel between any pair of locations. In the matrix the distances in *km* between locations are:

	A	B	C	D	E	F
A	–	9	6	11	10	14
B	9	–	5	6	15	23
C	6	5	–	5	10	18
D	11	6	5	–	9	17
E	10	15	10	9	–	8
F	14	23	18	17	8	–

Which pairs of locations should be linked by directly?

36. An individual is in S and wants to reach as soon as possible to a post office that can be either C1 or C2, as both are located nearby. In the network below the information about the problem is displayed, the numbers on the arcs represent the minutes needed to cross each link

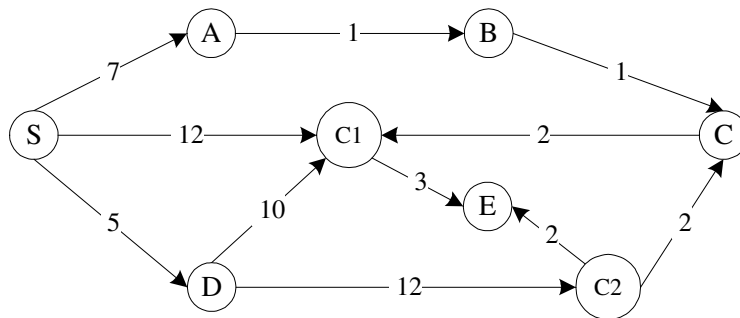

Determine which post office should the individual go and the path he should follow. Explain.

37. Solve the Minimum Cost Flow Problem represented in the following network, the parameters (c_{ij} , u_{ij}) are close to the arcs and b_i near the nodes:

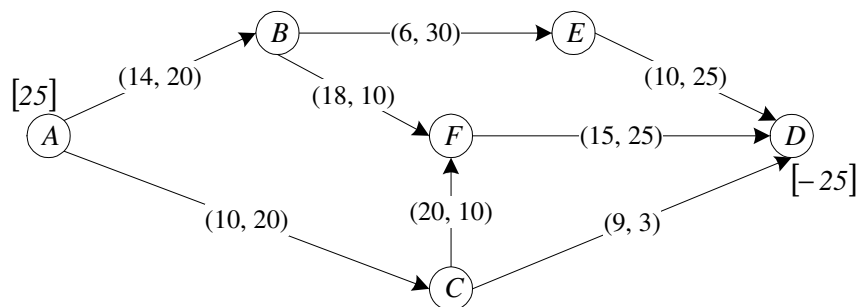

38. Consider a computer system which has a set of five terminals T1, T2, ..., T5 that must be connected to a central unit C. The connection to C may be direct or through other terminal.

- a) Formulate the problem of finding the set of connections with minimal cost as a network optimization problem.
- b) Find a set of direct connections if the costs (*m.u.*) are the following:

	C	T1	T2	T3	T4	T5
C	–	12	26	18	21	159
T1	12	–	400	I	I	112
T2	26	400	–	I	I	35
T3	18	I	I	–	22	23
T4	21	I	I	22	–	24
T5	159	112	35	23	24	–

(Note - I represents impossible connection)

39. A bank wants to link the computer terminals of its offices to the main office computer using special telephone lines. The telephone lines of each office do not need to be directly connected to the main office however it is necessary that communications could be established between any pair of computers. In the network below the nodes represent the offices (B,...,J) and the main office (A), the arcs represent the possible links and the values on the arcs the distances in kilometres. Knowing that the cost of a telephone line is proportional to the number of kilometres involved, determine the links that should be selected in order to minimize the total cost.

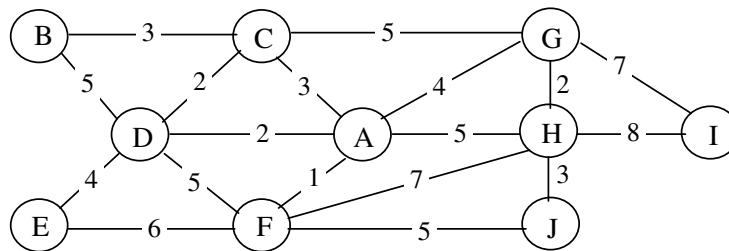

40. The company BUSE performs daily transportation of children from two schools (E1 and E2) to three local pre-school activities: an ATL, a gymnasium (G) and a music school (MS). To this end the company has two types of vans, the largest with a capacity for 20 children and that cost 10 *m.u.* per child, and those that carry up to 10 children at a cost of 25 *m.u.* per child. For logistical reasons any of the links is only done by a van and direct links between schools and activities in the gym and the school of music can only be done by smaller vans. The remaining connections are done with the larger vans. The following figure presents all possible links, representing each facility by a vertex numbered 1 through 5.

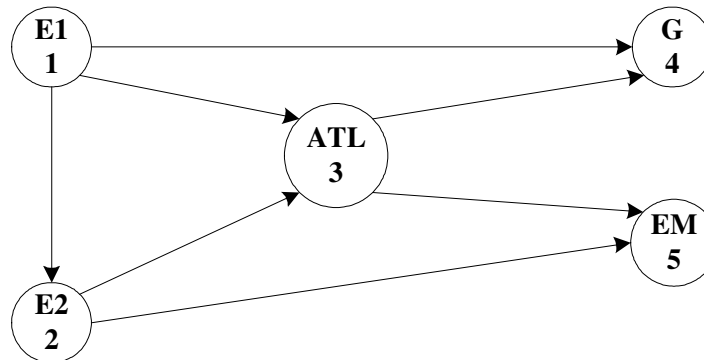

It is known that the number of children waiting to be transported from the E1 and E2 is equal to 20 and 10, respectively. In ATL there are 15 children. Of these, 10 must be transported to the gym or the



school of music and the other five must remain there. In turn, 25 children are expected in the gym and 15 in the music school.

- a) Formulate the problem as a network optimization problem.
- b) Formulate the problem as an LP.
- c) Find the optimal solution by Solver.

41. A plant just bought an equipment to produce a new product that has been patented for the coming four years. Management wants to determine the best equipment replacement strategy during that period, assuming that at the end the equipment is sold by its salvage value. The next table displays the equipment salvage value according to its use (age), as well as the other annual costs associated to its use and maintenance. The cost of a new equipment is 100 *m.u.* (salvage value of year 0).

equipment age (in years)	1	2	3	4
salvage value (in <i>m.u.</i>)	50	25	10	5
use and maintenance costs (in <i>m.u.</i>)	40	50	70	100

- a) Give a solution for the equipment replacement problem and the respective cost.
 - b) Formulate as a network optimization problem and a linear programming problem.
42. A company produces a commodity in two factories, located in Lisboa and Porto. it is then shipped to warehouses, in Coimbra and Évora, or directly to the shops in Beja and Guarda. In the table below the data about the problem is displayed, including the quantities supplied and demanded (in *ton*), as well as the distances (in *km*) of the available connections (it is possible to go from Porto to Coimbra but the reverse, Coimbra to Porto, is not allowed)

Distances (*km*)

	Porto	Coimbra	Évora	Guarda	Beja	Supply (<i>ton</i>)
Lisboa	310	200	130		180	1000
Porto		110		200		1500
Coimbra			290	150	340	
Évora					80	
Guarda					360	
Demand(<i>ton</i>)				1100	1300	

Assuming that the transportation cost is proportional to the distance, formulate the problem that should be solved to optimize the distribution of the product:

- a) As an LP problem.
- b) In the following *Excel* sheet, write the *Excel* formulas and fill in the *Solver* Window.



	A	B	C	D	E	F	G	H	I	J	K	L	M	N
1														
2														
3														
4														
5														
6														
7														
8														
9														
10														
11														
12														
13														
14														
15														
16														
17														

Solver Parameters

Set Target Cell:

Equal To: Max Min Value of:

By Changing Cells:

Subject to the Constraints: